

C. V. WOERD.

MACHINE FOR TURNING WATCH CASE CENTERS.

No. 301,314.

Patented July 1, 1884.

Fig. 1.

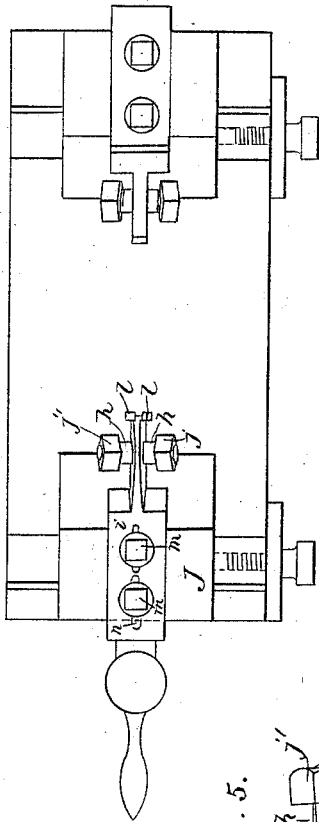

Fig. 2.

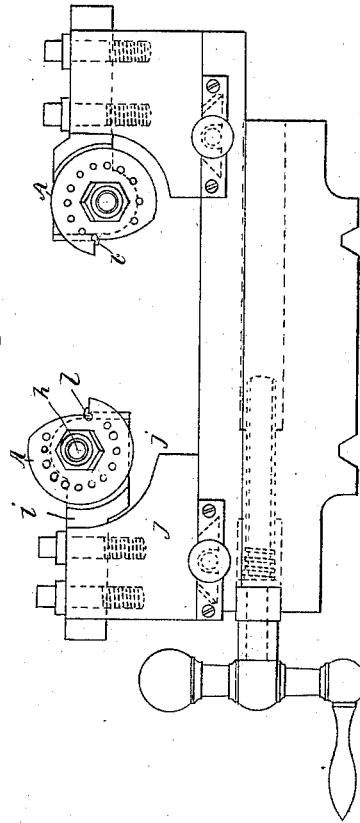

Fig. 5.

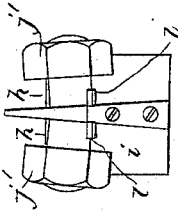

Fig. 4.

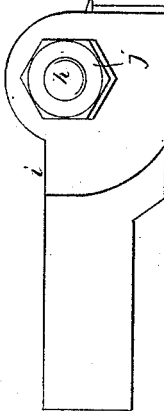
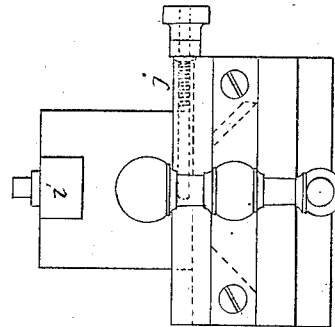

Fig. 3.



Witnesses.
 John M. Snodgrass
 Alfred L. White

Inventor.
 C. V. Woerd
 by Wright & Brown
 Attys

C. V. WOERD.

MACHINE FOR TURNING WATCH CASE CENTERS.

No. 301,314.

Patented July 1, 1884.

Fig-6.

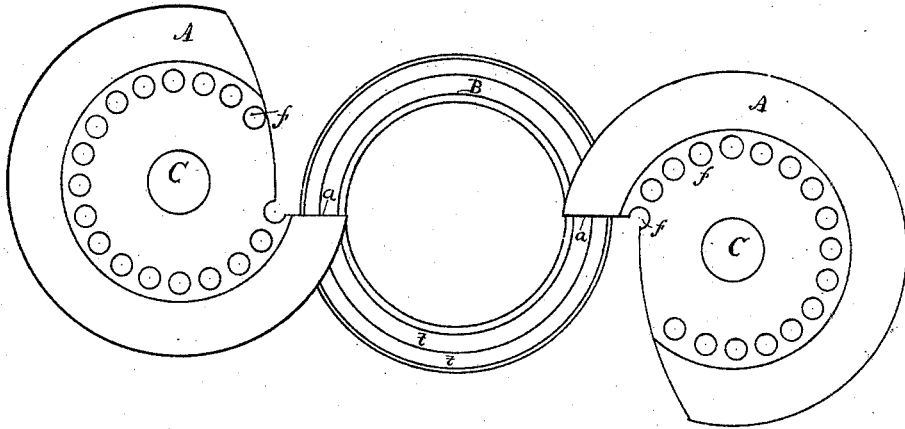
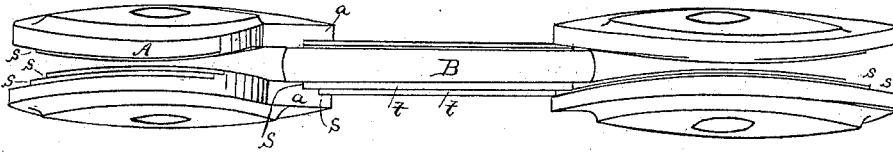

Fig-7.



Witnesses.

*John M. Fishay
 Alfred L. White*

Inventor.

*C. V. Woerd
 by Wright & Bonner
 Atty*

UNITED STATES PATENT OFFICE.

CHARLES V. WOERD, OF WALTHAM, MASSACHUSETTS, ASSIGNOR TO THE
AMERICAN WATCH COMPANY, OF SAME PLACE.

MACHINE FOR TURNING WATCH-CASE CENTERS.

SPECIFICATION forming part of Letters Patent No. 301,314, dated July 1, 1884.

Application filed August 29, 1883. (No model.)

To all whom it may concern:

Be it known that I, CHARLES V. WOERD, of Waltham, in the county of Middlesex and State of Massachusetts, have invented certain Improvements in Machines for Turning Watch-Case Centers, of which the following is a specification.

This invention has for its object to provide improved means for forming shoulders or snap-edges on watch-case centers, to fit the snap-edges on the backs, covers, and crystal rims or holders. It is very essential that in every case of a given pattern absolute uniformity in the shoulders or snap-edges of the case-center be preserved.

My invention consists in the improved cutter hereinafter described, and in the relative arrangement of said cutters in pairs, whereby the desired uniformity is attained, as I will now proceed to describe.

Of the accompanying drawings, forming a part of this specification, Figure 1 represents a plan view of a center-turning rest embodying a part of my invention, the cutters being removed. Fig. 2 represents a front elevation of the same, showing the cutters in place. Fig. 3 represents an end view of the same. Figs. 4 and 5 represent detail views. Fig. 6 represents an enlarged elevation of my improved cutters, showing their working position with relation to the case-center on which they operate; and Fig. 7 represents a top view of the same.

The same letters of reference indicate the same parts in all the figures.

In carrying out my invention I employ cutters A of the same general construction as that shown in Letters Patent of the United States granted to me November 28, 1882, No. 218,339, each cutter being composed of a circular plate or disk cut away or notched at one side, as shown, one side, *a*, of the notch being radial, or nearly so, and forming a sufficient angle with the perimeter and sides of the plate to constitute a cutting-edge. At the center of the plate A is an orifice, *c*, which is concentric with the perimeter, and receives a pin or stud which supports the cutter. The plate is provided with a concentric series of holes, *f*, for

the purpose described in my above-named patent. On the inner side of each cutter are formed one or more annular shoulders, *s*, which intersect the edge *a* and form one or more angles, *s'*, thereon, thus adapting said edge to form corresponding shoulders, *t*, on a rotating watch-case center, B, to which it is presented. I arrange the described cutters in two pairs adapted to operate simultaneously at diametrically-opposite points on the case-center, as shown in Figs. 6 and 7. The two cutters composing each pair are placed side by side on studs *h h*, formed on a stock or bar, *i*, adjustably secured to a slide-rest, *j*. The studs *h h* are inclined in different directions, as shown in Fig. 5, so that the proximate sides of the cutters of each pair stand at different degrees of inclination. The shoulders *s s* are on the inner or proximate sides of the cutters, as shown in Fig. 7. The stocks *i i* are provided with stops or gages *l l*, which bear upon the edges *a* of the cutters and determine the position of said edges when they are placed upon the studs. The cutters are confined by clamping-nuts *j'* upon said studs. The stocks *i i* are rendered adjustable toward and from each other to adapt the cutters to different sizes of case-centers by means of set-screws *m m*, entering the center-rests, and slots *n n* in said stocks, through which said screws pass. The case-center B to be operated on is held on a suitable chuck, *o*, between the pairs of cutters, and is rotated until the angular cutting-edges *s'* of the cutters form the shoulders *t* on the opposite sides of the case-center. Both sides of the case-center are thus finished simultaneously, and all the centers formed by the cutters during a given adjustment will be exactly alike in regard to the depth and form of the shoulders and the thickness of the case in cross-section, or from the shoulder at one side of the case through the case to the opposite shoulder. Perfect uniformity and rapidity are thus attained, and nothing in regard to proportion is left to the judgment of the operator. The described form of the cutters and the provision of the annular shoulders upon their inner sides enable them to be easily ground and retain exactly the same form at their cutting-

edges until they are worn out. The different inclinations of the proximate sides of the cutters in each pair cause the sides of the cutters to diverge from the case-center, so that only the cutting-edges of the cutters will come in contact therewith. Frictional contact between the case-center and the sides of the cutters is thus prevented, and wear of the sides of the cutters is obviated.

I do not limit myself to inclining the cutters, however, as their proximate sides may be parallel, if preferred. It is obvious that a single cutter having the described marginal form and provided with the annular shoulder or shoulders on one side may be used independently without departing from the spirit of my invention; also, that a single pair of such cutters may be used instead of two pairs. When two pairs are used, as shown, one pair is preferably formed to partially form the shoulders on the case-center, and the other pair to finish said shoulders.

I claim—

1. A lathe-cutter composed of a circular plate notched to leave a segmental margin and form a radial or nearly radial cutting-edge, and provided on one side with one or more annular shoulders intersecting said cutting-edge, and enabling the latter to form corresponding shoulders on a watch-case center, as set forth.

2. In an organized machine for turning watch-case centers, a pair of cutters, each composed of a circular plate notched to leave a segmental

margin and a radial or nearly radial cutting-edge, the said cutters having annular shoulders on their proximate sides intersecting said cutting-edges, and enabling the latter to simultaneously form corresponding shoulders on the opposite sides of a watch-case center, as set forth.

3. In an organized machine for turning watch-case centers, a pair of cutters, each formed substantially as described, to cut shoulders on the opposite sides of a case-center, and relatively inclined, as described, whereby the side of each cutter is cleared from the case-center, excepting at the cutting-edge, as set forth.

4. In an organized machine for turning watch-case centers, two pairs of cutters, formed substantially as described, and arranged to act simultaneously on the case at diametrically-opposite points, as set forth.

5. The combination of a chuck adapted to hold a watch-case center, two adjustable slide-rests, each having two differently inclined studs, *h h*, and stops *l l*, and cutters *A A*, formed as described, adjustably secured to said studs, and having cutting-edges bearing against said stops, as set forth.

In testimony whereof I have signed my name to this specification, in the presence of two subscribing witnesses, this 14th day of June, 1883.

CHAS. V. WOERD.

Witnesses:

C. F. BROWN,
A. L. WHITE.